

RANGE COMPOSITION

A range which combines experience and innovation; is excellent in quality and economical in use. The ideal solution for establishments requiring ovens with high output, compact dimensions, flexibility of use, high levels of automation, reduced energy and condiments consumption, up-to-date design and maximum reliability.

The range consists of six 6 grid models, three electric and three gas, ideal for all types of traditional oven cooking, roast meat, cakes, pizzas, fish, vegetables, grilled food, "au gratin" cooking and the reconditioning of chilled and frozen food.



FCF-6

FORCED AIR CONVECTION OVENS **ZANUSSI** PROFESSIONAL

FUNCTIONAL AND CONSTRUCTION FEATURES

◆ The Flow Channel ventilation system guarantees uniform cooking of food by optimizing the flow of air and diffusion of heat throughout the oven chamber, it also means that it is possible to cook different foods at the same time without transfer of smell or flavour.

◆ External panelling, door, sides and upper part in 304 AISI stainless steel; the cooking chamber, grid supports, diffusers, and the fan walls are in 430 AISI stainless steel; the single glazed door is made from tempered glass and gives an excellent view of the cooking load and a door opening safety device. The oven chamber has rounded corners and no joins for ease of cleaning.

◆ Space saving: Maximum use is made of the internal space due to the particular dimensions of the oven chamber and to the availability of

different types of internal structures; the oven chamber has rounded corners and no joins for ease of cleaning.

TECHNICAL DATA						
CHARACTERISTICS	MODELS					
	FCF61G 240200	FCF061GMS 240222	FCF61E 240205	FCF061ENS 240226	FCF061ELN 240211	FCF61GT 240260
Power supply	Gas	Gas	Electric	Electric	Electric	Gas
Functional level	Base; Manual	Base; Manual	Base; Manual	Base; Manual	Base; Manual	Base; Manual
Type of grids	1/1 Gastronorm	1/1 Gastronorm	1/1 Gastronorm	1/1 Gastronorm	1/1 Gastronorm	1/1 Gastronorm
Shelf capacity	6	6	6	6	6	6
Cooking cycles - °C						
air-convection	300	300	300	300	300	300
Convection	●	●	●	●	●	●
External dimensions - mm						
WxDxH	860, 746, 701	860, 746, 701	860, 746, 633	860, 746, 633	860, 746, 633	860, 746, 701
Internal dimensions - mm						
width	560	560	560	560	560	560
depth	370	370	370	370	370	370
height	380	380	380	380	380	380
Power - kW						
electric	0.35	0.35	7.7	7.7	7.7	0.35
cooking chamber	8.5	8.5	7.5	7.5	7.5	8.5
gas	8.5	8.5				8.5
Net weight - kg.	92.1	92.1	79.5	79.5	79.5	92.1
Supply voltage	220/230 V, 1N, 50	220/230 V, 1N, 60	400 V, 3N, 50	400 V, 3N, 60	230 V, 3, 50	220/230 V, 1N, 50
Town Gas						●

- ◆ The optimised relationship between installed power, output and speed of cooking means that excellent results can be achieved in terms of economy of use as well as the production in a short amount of time of a high quantity of food.
- ◆ The heating system in the gas models consist of atmospheric burners for grilling effect; safety is guaranteed by flame failure device; main burner ignition by pilot light; piezoelectric ignition of the pilot light. The heating system in electric models consists of "Incoloy" armoured elements positioned on the convector unit.
- ◆ Main switch/Cooking mode selector which can be used to set: ON/OFF, convection without humidification and convection with humidification (choice of 5 different humidity levels).
- ◆ Rapid cooling of the oven by air with the door open.
- ◆ The oven is designed to be fitted with a probe which is available as an accessory.
- ◆ Gas models are supplied for use with natural gas, with LPG conversion jets supplied as standard.
- ◆ Side lighting system using normal bulbs; press-button door opening and closing system. Electromechanical thermostat with an operating temperature adjustable from 30°C to 300°C.

- ◆ Timer to set the cooking time, adjustable up to 120 minutes or for continuous operation with an acoustic alarm to show the cycle has finished. At the end of the set cooking time the heat and the fan are automatically switched off.
- ◆ The humidity level can be set by selecting one of the 5 levels shown on the control panel; it functions by injecting water into the cooking chamber for a few seconds every minute.

- ◆ 1 pair of 60 mm pitch runners is supplied as standard.
- ◆ All models comply with the standards required by the main international approval bodies and are CE marked.

OPTIONAL ACCESSORIES						
ACCESSORIES	MODELS					
	FCF61G 240200	FCF061GMS 240222	FCF61E 240205	FCF061ENS 240226	FCF061ELN 240211	FCF61GT 240260
1 GRID GN1/1 FOR 8 WHOLE CHICKENS(1.2KG)	922266	922266	922266	922266	922266	922266
1/1GN DRAIN PAN GUIDE KIT	921713	921713	921713	921713	921713	921713
2 FRYING BASKETS FOR OVENS	922239	922239	922239	922239	922239	922239
2 GRIDS GN 1/1 FOR CHICKENS (8 PER GRID)	922036	922036	922036	922036	922036	922036
AUTOMATIC WATER SOFTENER FOR OVENS	921305	921305	921305	921305	921305	921305
BASE FOR OVEN 6X1/1	922101	922101	922101	922101	922101	922101
EXTERNAL SIDE SPRAY UNIT	922171	922171	922171	922171	922171	922171
FAT FILTER FOR OVEN 6 GN	922177	922177	922177	922177	922177	922177
FEET FOR OVENS 6&10 GN1/1-10 GN2/1	922127	922127	922127	922127	922127	922127
FRYING GRIDDLE GN 1/1 FOR OVENS	922215	922215	922215	922215	922215	922215
PAIR OF 1/1 GN AISI 304 S/S GRIDS	921101	921101	921101	921101	921101	921101
PAIR OF 1/2 GN PAN SUPPORT SHELVES	921106	921106	921106	921106	921106	921106
PROBE FOR OVENS 6-10X1/1	921702	921702	921702	921702	921702	921702
RESIN SANITIZER FOR WATER SOFTENER	921306	921306	921306	921306	921306	921306
RETRACTABLE HOSE REEL SPRAY UNIT	922170	922170	922170	922170	922170	922170
SHELF GUIDES FOR 6X1/1-OVEN BASE	922105	922105	922105	922105	922105	922105
WATER FILTER FOR OVENS 0.8 L/MIN.	922186	922186	922186	922186	922186	922186



www.zanussiprofessional.com

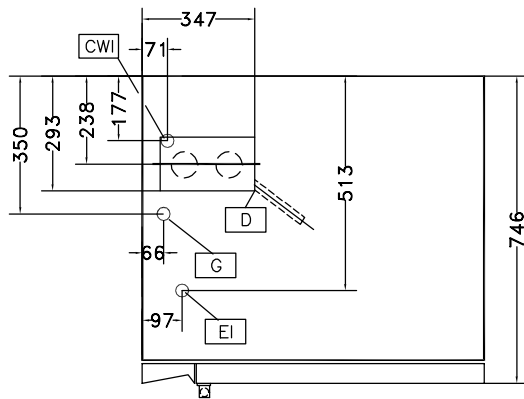
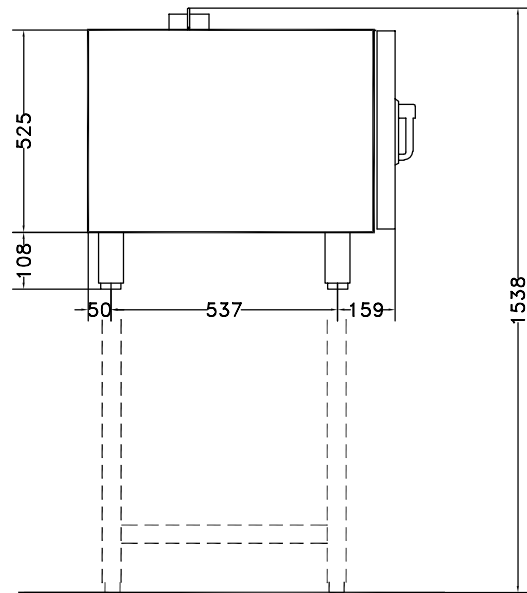
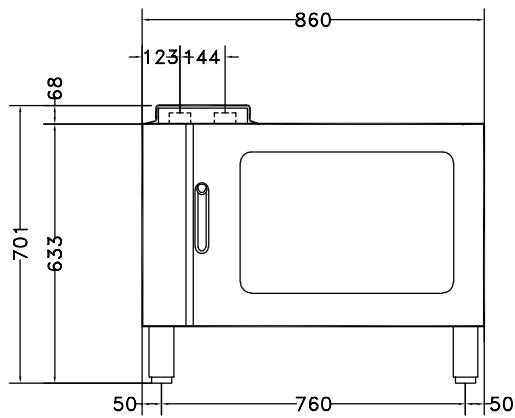

ITC-S22036

LEGEND

	FCF61G 240200	FCF061GMS 240222	FCF61GT 240260
CWI - Cold water inlet	3/4"	3/4"	3/4"
D - Water drain	25mm	25mm	25mm
EI - Electrical connection	220/230 V, 1N, 50	220/230 V, 1N, 60	220/230 V, 1N, 50
G - Gas connection	1/2"	1/2"	1/2"



www.zanussiprofessional.com

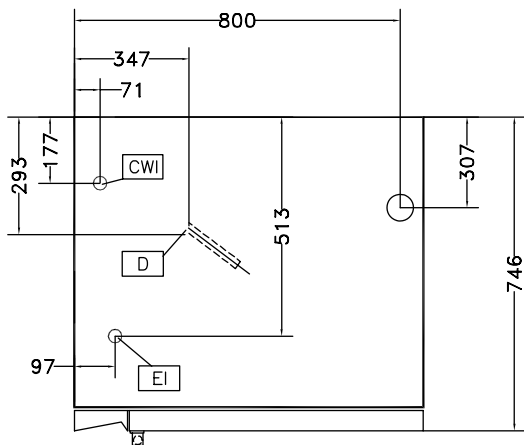
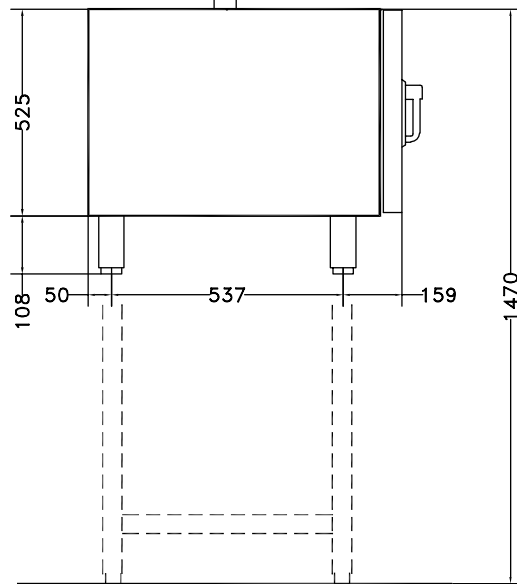
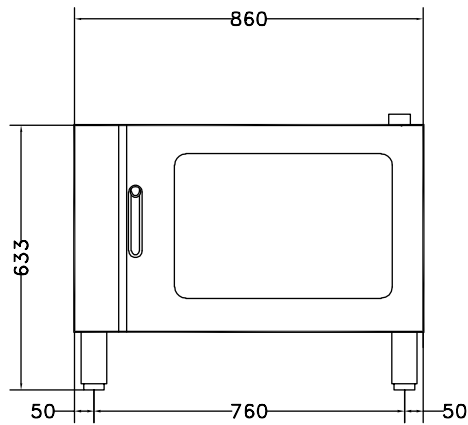

ITC-S22041

LEGEND

	FCF61E 240205	FCF061ENS 240226	FCF061ELN 240211
CWI - Cold water inlet	3/4"	3/4"	3/4"
D - Water drain	25mm	25mm	25mm
EI - Electrical connection	400 V, 3N, 50	400 V, 3N, 60	230 V, 3, 50



www.zanussiprofessional.com